

Please Register Online at: [www.X-Arcade.com](http://www.X-Arcade.com)

You will get updates on technical info, be verified for your lifetime warranty, new game releases, new adapter releases and new products compatible with X-Arcade™ technology!

Last Minute Updates Can Be Seen At Our Website:

We have added a new test program online. Please download this program for testing out your X-Arcade™.

Check with your nearest retailer or order online at [www.XGaming.com](http://www.XGaming.com)

The X-Arcade™ product, concept and shape are all protected by International Patent/ Trademarks and/or provisional pending patent applications. Please contact [legal@xgaming.com](mailto:legal@xgaming.com) for any info on such violations.

XGAMING, INC® Copyright © 2002. All Rights Reserved. X-Arcade™ is protected by one or more US and International Patents/pending patents and trademark/copyright. XGAMING® X-MST™ Multiple System Technology is protected by one or more U.S and International Patents or pending patents. Any violation of copyright, trademark or patent laws in U.S, Europe or Asia will be prosecuted to the fullest extent of the law. SW1 2002 V1.1

## TABLE OF CONTENTS

<b>X-ARCADE OVERVIEW</b>	<b>3</b>
<b>X-ARCADE SPECIFICATIONS</b>	<b>4</b>
<b>SETUP - CONNECTING TO A GAME SYSTEM</b>	<b>5</b>
<b>SETUP - CONNECTING TO A COMPUTER</b>	<b>6</b>
<b>OPERATION W/ GAME CONSOLE</b>	<b>8</b>
<b>OPERATION W/ COMPUTER</b>	<b>9</b>
<b>PROGRAMMING THE X-ARCADE</b>	<b>10</b>
<b>SYSTEM LEGENDS – ANALOG/DIGITAL INSTRUCTIONS</b>	<b>12</b>
<b>TROUBLESHOOTING</b>	<b>14</b>
<b>WARRANTY</b>	<b>16</b>

## THANK YOU FOR YOUR PURCHASE

The XGAMING® Inc. team is excited to bring the X-Arcade™ Authentic Arcade Experience into your home. With the high end, commercial grade design of X-Arcade™ and our commitment to develop adapters for all game systems, the X-Arcade™ should be in your home for a very long time.

## IMPORTANT – READ BEFORE INSTALLATION

- The X-Arcade™ ships standard with the ability to work with a personal computer. Additional adapters are available to connect the controller to game consoles such as the Playstation 2™, XBOX™, Dreamcast™, and GameCube™. The X-Arcade™ and/or other X-MS™ products are only compatible with XGAMING® branded, X-MS™ adapters. Please visit [www.XGaming.com](http://www.XGaming.com) for authorized resellers and distributors.
- When you purchase a new game system, like XBOX 2 or Playstation 3, be sure to visit: **[www.XGaming.com](http://www.XGaming.com)** for new adapter availability.
- **PC ONLY:** The X-Arcade™ plugs into a standard PS/2 keyboard port on a computer. If your keyboard does not fit, you can purchase an off the shelf AT-PS/2 adapter. If you have problems using the X-Arcade™ with your PS/2 keyboard port, you can get our USB Adapter.
- **ADVANCED USERS:** For programming your X-Arcade™, please pay close attention to the directions. Most notably, when switching between MEMORY MODES you must press the LOAD button located on the back panel of the X-Arcade™ 2 (TWO) times to activate the MODE.
- *When using your X-Arcade™ with a game console, make sure to note the section on Digital/Analog, which will alleviate many issues you may encounter.*
- Using with Emulation (PC Only). In the emulator, choose X-Arcade™ as your controller from the options-controls menu. If you need help with using your X-Arcade™ with certain software or games, be sure to visit the Support and Arcade Center sections of our website – [www.XGaming.com](http://www.XGaming.com)
- Playing with a game console. It's important to remember to turn off your console before plugging in any controller.
- **DO NOT** clean with any ammonia based products such as Windex.

## X-ARCADE™ OVERVIEW

Included in this Kit:

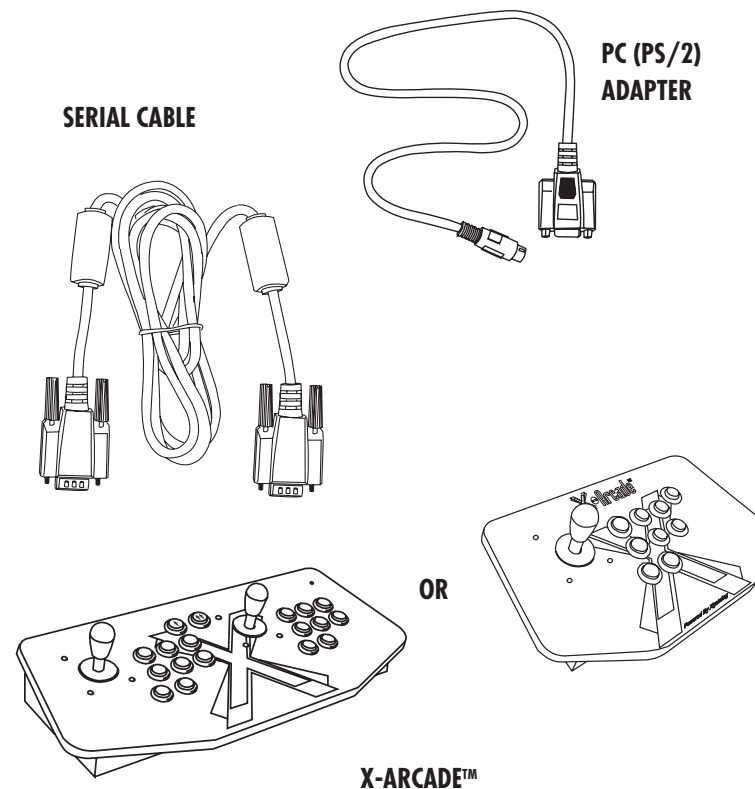

When connecting to a PC, the X-Arcade™ works by acting as A KEYBOARD. So, do not get confused with references to it being called "The Ultimate Controller", because inside it's setup like a keyboard, and your computer thinks it's a keyboard. It is, however, a normal game controller when you use one of the X-Arcade adapters, which are included in this kit.

## X-ARCADE SPECIFICATIONS

### Arcade Quality Buttons™

- Designed and manufactured for use with the X-Arcade™ unit.
- 1 and 2 player buttons to simulate the arcade feel.
- Replace on site with any arcade grade buttons/switches.
- Lifetime warranty if registration is filled out online.
- Left and right side pinball buttons to replicate arcade pinball machine for applicable games.

### Authentic Arcade Quality Joysticks™

- Arcade controllers designed and molded for the X-Arcade™, working like standard arcade parts from a real arcade.
- 10,000,000 cycle testing and usage.
- Lifetime warranty.
- Commercial grade components replaceable with any arcade joystick.

### Proprietary X-Adapter™ and X-Chip™ System

- Our patented X-Chip technology built into the X-Arcade™ provides support for external use with any next-generation gaming console currently available, and allows us to continue to support upcoming systems as well.
- Uses standard serial connection from X-Arcade™ to the X-Adapter™, with adapters then converting the signal to any gaming console.
- X-Adapters™ provide built in support for two players, so the X-Arcade™ will work with dual player usage on any gaming system.

## SETUP - CONNECTING TO A GAME SYSTEM

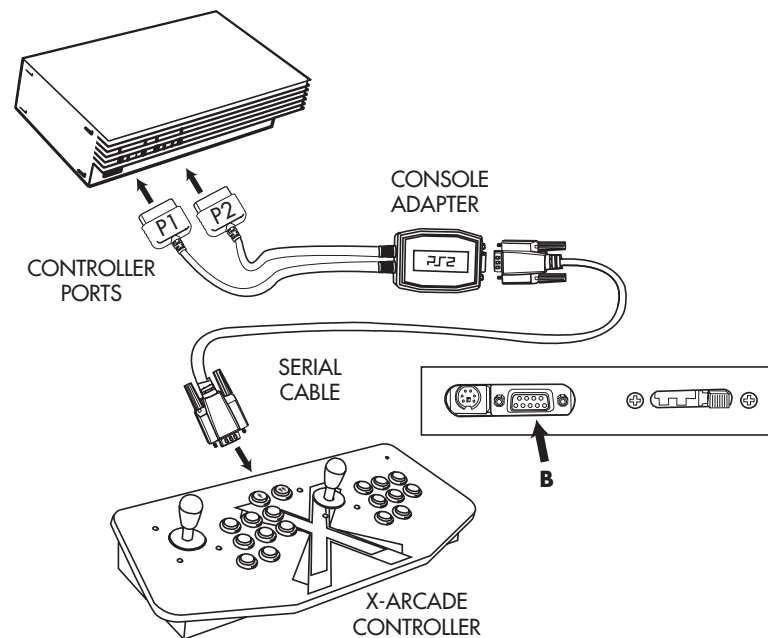

**Make sure your game system is powered off before attempting to connect anything to the console.**

- 1) Insert the game console adapter cords labeled "P1" and "P2" into your game system's respective "player" controller ports. (Only the "P1" side is used for the Solo™ controller.)
- 2) Plug the black serial cable into the back of the game console adapter.
- 3) Plug the other end of the black serial cable into the back of the X-Arcade in port **B** shown above.
- 4) Power on the game system, a red LED should light on the X-Arcade
- 5) **PLAY!**

## SETUP - CONNECTING TO A COMPUTER

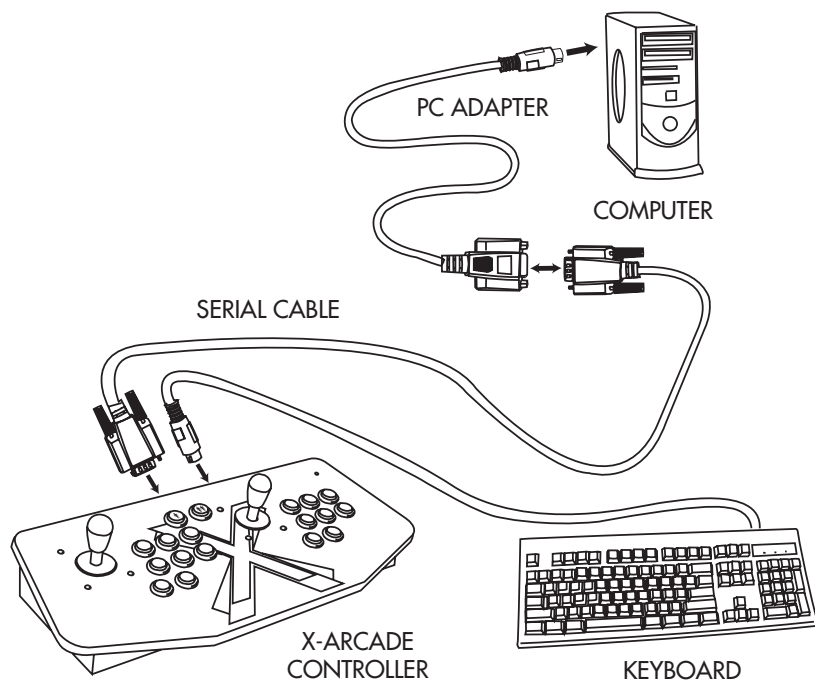

**Make sure your computer is first turned off before attempting to unplug or plug in anything. You must have a PS/2 Keyboard plugged into the X-Arcade.**

- 1) Unplug keyboard from the back of your computer.
- 2) Plug your keyboard (PS/2 connector) into the X-Arcade ( **A** in diagram).
- 3) Attach the two black cables included with the X-Arcade **TOGETHER** (PC Adapter to serial cable).
- 4) Plug the X-Arcade's included PC Adapter into your computer's PS/2 keyboard port.

X-ARCADE CONTROLLER

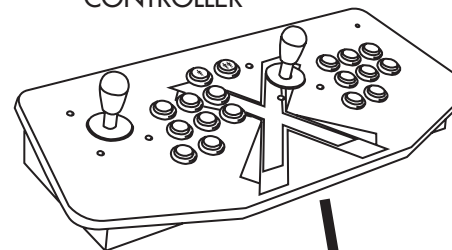

BACK VIEW

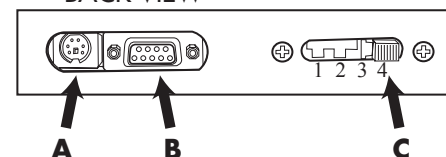

### A. Keyboard Input

This is where you **PLUG IN** your PS/2 Keyboard. (note, if you do not have a PS/2 Keyboard, you can purchase an AT-PS/2 adapter and a PS/2-AT adapter) Use this only if you are planning to use the X-Arcade with a personal computer.

### B. Serial Cable Port:

This is where the included **SERIAL CABLE** is plugged in. The other end of the serial cable then plugs into either the included **PC Adapter** (PS/2 keyboard port) or **USB Adapter** (sold separately) for PC use, or into a console X-Adapter™ (sold separately) for console use .

### C. Mode Selector Switch (PC only):

This is the **MEMORY Manager** for PC use. **MODE 1** is default and **NOT PROGRAMMABLE**. Modes 2, 3, and 4 are programmable. To Load a **MODE**, make sure to **PRESS LOAD BUTTON TWICE!** Modes are counted 1-4 as in picture.

## OPERATION WITH GAME CONSOLES

Convert your Playstation®, Playstation®2, XBOX™, GameCube™, Dreamcast™ and more into an arcade experience! Simply add the X-Adapter™ for the specified system and you will feel like you are playing at the arcades.

On gaming consoles, the unit operates just like a standard gamepad, with buttons assigned to the arcade buttons.

See the appendix for the appropriate button legend for your game system.

### Digital vs. Analog Control Overview:

Handheld controllers for newer game systems feature both digital and analog controlling devices. On the Playstation® Dual Shock™ controller, for example, There is a D-pad and two analog thumbsticks. Most games use the D-pad and/or left thumbstick to operate a game. The X-Arcade™ controller features only one digital joystick per player, therefore adjustments need to be made to select whether this joystick functions as the D-pad or the left analog thumbstick. Some games may require the use of 2 control devices simultaneously, we recommend using the standard handheld controller for such games. Switching between digital and analog control is easy, and is slightly different for each console. *See the key legends in the appendix for directions on switching between analog and digital on each console, but in general:*

**Most Adapters (XBOX™, GameCube™, Playstation®) switch like this:**

**Side Button + Top-left Button 1 = Digital**

**Side Button + Top 2nd Button = Analog 1 (primary thumbstick)**

**Side Button + Top 3rd Button = Analog 2 (secondary thumbstick)**

## OPERATION WITH A COMPUTER

On a **PC** or **MAC**, the buttons are assigned to a specific keystroke. When you press a button on the X-Arcade™, your computer is under the impression you are pressing a button on your keyboard.

Slide the switch on the back of the X-Arcade™ closest to the serial connector for Default MODE 1. Most games will work fine using only Mode 1. To reach programmable modes 2, 3, and 4 (which are default NOT SET TO ANY KEYS), just slide the switch away from the serial connector.

For most games on your computer, you will need to change the button assignment to the actions or functions you wish for them to perform within the game itself. If the game does not have an option to use the keyboard keys you want, you can simply use the hardware programming on the X-Arcade™. Programming for each game and how to get to each game's menu would be impossible, so it's important to read this once and understand the underlying form:

To setup in software: the first time you play the game, you must go to the game's options menu. Most likely it will say something along of the lines of **SETUP, SETUP CONTROLS, OPTIONS, CONTROLS**, etc. and lead you to the menu for assigning actions in games. The majority of windows games require that you first start the game, and then press either **ESC** or go to the main menu, where there will be some sort of icon that represents the **OPTIONS** for the game or the **CONTROLS** for the game.

Once you find the game's **OPTIONS**, and subsequently, the game's **CONTROLS**, you must understand how to change the game's pre-programmed default keys to the keys on the X-Arcade™. Make sure the controls in the game are set to keyboard, **NOT A MOUSE OR JOYSTICK**, as the X-Arcade™ is seen as a keyboard by your PC. Understand this only needs to be done once, and never again, so you should understand the concept so you can do it easily on other games. If you look at the diagram for the X-Arcade™ and see which buttons are assigned to which keys. Example, **LEFT CONTROL** key of keyboard is actually the **1 PLAYER** Main Action button, so if you want to have that first top left button assigned to a function like **FIRE** or **ACTION**, just highlight the action you wish to perform, **FIRE** (or similar), then in some fashion it will then ask you to pick the key or button you wish to assign it to, then press the button on the arcade. You must do this for **PLAYER 1** and **PLAYER 2** (if you are playing a 2 Player game) and set up all the actions you wish to use.

## PROGRAMMING THE X-ARCADE (ADVANCED USERS)

The X-Arcade™ has 4 memory banks. Mode 1 is factory programmed and non-changeable. Modes 2-4 are fully programmable as many times as you want.

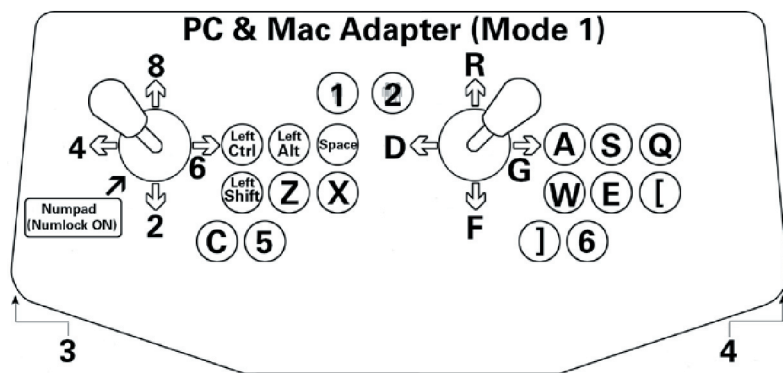

**NOTE** When switching between modes by sliding the toggle, you must press a button on the back of X-Arcade™ to change modes. Press the LOAD BUTTON 2 times.

### Programming:

When the LED is on, you are in play mode. When the LED is off you are in program mode.

Remember that MODE 1 (switch closest to the serial cable) cannot be programmed.

The keyboard must be plugged into the back of the X-Arcade to program it.

To change modes, you must slide the switch on the back to desired Mode position, and then press the SAVE/LOAD button TWICE to load that mode.

Programming is for the PC only, and does not function on game consoles.

Start By Choosing Mode 2, 3 or 4 by sliding the switch toward the single button on back.

1. Press the black button (LOAD BUTTON) on the back of X-Arcade™ (the red LED turns off).
2. Press and hold any button (or direction on a joystick: UP, DOWN, LEFT or RIGHT) on the X-Arcade™ that you wish to change (keep holding during Step 3!).
3. While still holding button in Step 2, press and hold a key on the keyboard until the LED light on the X-Arcade™ starts to blink. Once the light starts blinking, the button on the X-Arcade™ has been programmed to the keyboard button selected in step 2. Release both held buttons.
4. Repeat steps 2 & 3 to program additional buttons. (Do not press load again)
5. Press the LOAD BUTTON to close out and save your entire programmed mode!

**NOTE:** If you want to change a mode after programming, you must press the LOAD BUTTON 2 (TWO) TIMES. Don't forget this step. Remember to HOLD THE BUTTON ON X-ARCADE™ TOGETHER UNTIL LED FLASHES.

All the programmed buttons will be saved permanently in the X-Arcade's on board memory. If you turn off the computer, or unplug the X-Arcade™, the programmed buttons will not be lost. The X-Arcade™ can be reprogrammed as many times as you like. This hardware based function was designed to allow easy use with any Operating System. So, read it over a few times. Otherwise, you can also just assign keys in each individual game.

## CONSOLE LEGENDS

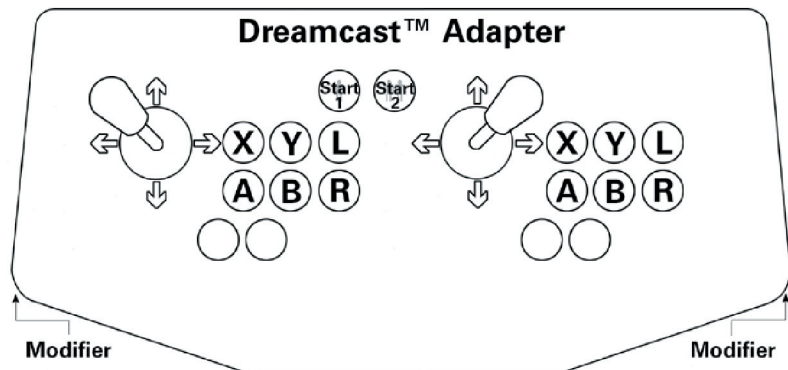

Press the Modifier button to switch between digital (D-PAD) and Analog movements)

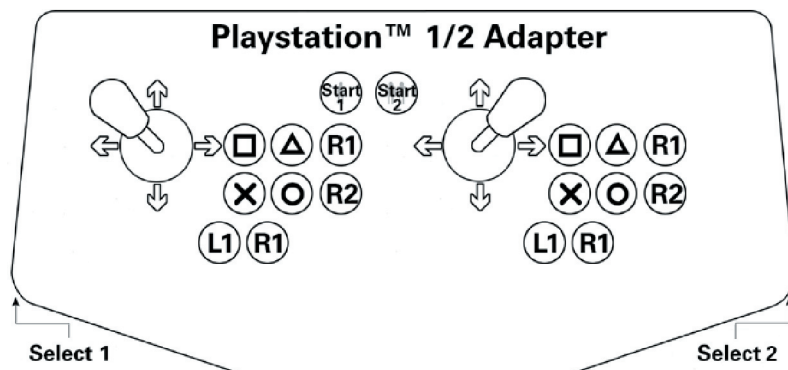

Select + □ = D-PAD (default)  
 Select + △ = Analog 1 (Left Thumbstick)  
 Select + R1 = Analog 2 (Right Thumbstick)  
 Select + Start = True Digital Mode (PSX)  
 Select + L1 = Slow Sensitivity for Analog 1  
 Select + L2 = Normal Sensitivity for Analog 1

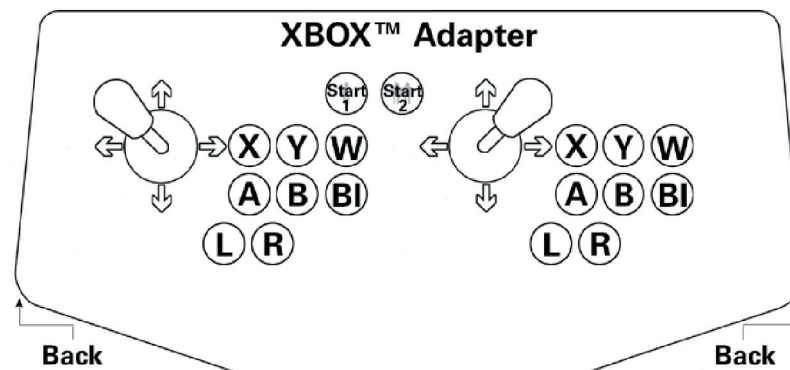

Back + X = D-PAD (default)  
 Back + Y = Analog 1 (Left Analog Thumbstick)  
 Back + W = Analog 2 (Right Analog Thumbstick)  
 Back + L = Slow Sensitivity for Analog 1  
 Back + R = Normal Sensitivity for Analog 1

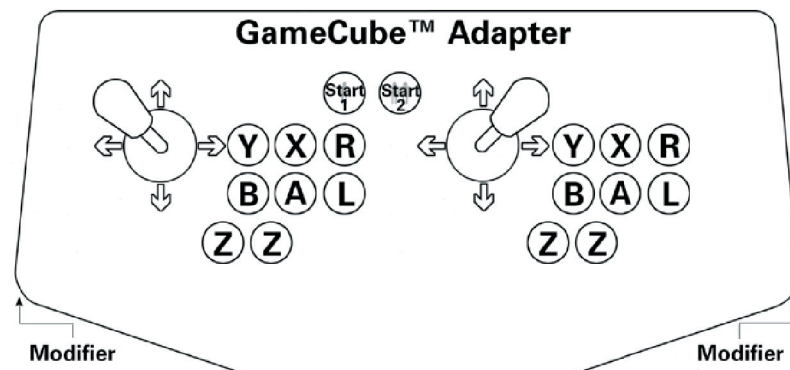

Modifier + Y = D-PAD (default)  
 Modifier + X = Analog 1 (Left Thumbstick)  
 Modifier + R = Analog 2 (Right Thumbstick)  
 Modifier + Start = Toggles analog switches for R & L buttons (default on)  
 Modifier + Left Z button = Slow Sensitivity for Analog 1  
 Modifier + Right Z button = Normal Sensitivity for Analog 1

## TROUBLESHOOTING

Toll Free Technical Support 1-866-942-6464 (M-F 9-5 Eastern Time) or refer to the Customer Service section at [www.x-arcade.com](http://www.x-arcade.com) for more updated support answers to frequently asked questions.

Here are some suggestions if you are experiencing problems:

- Make sure you have a functioning, working keyboard plugged into the X-Arcade™ for PC use.
- Any time you connect or disconnect the product, **TURN OFF THE SYSTEM!**
- Make sure all your connections are tight and secure.
- Make sure your X-Arcade's™ serial cable is plugged into the **KEYBOARD'S PS/2 PORT** (not mouse). And all connections are made to correct ports!
- If the keyboard lights up, and you can press **THE CAPS LOCK/NUM LOCK** and see the light flash, and the X-Arcade's™ **LED** light is on, you should have a secure, tight connection. If not, check and make sure everything is plugged in/powering on correctly.
- Sometimes, Windows® produces some unique effects by pressing the Shift button too many times in a sequence. If this happens, make sure to disable **STICKY KEYS™** (it will pop up if you have a problem). Note this is a Windows issue and not an issue with the X-Arcade™.
- Other use: If you still can't get the X-Arcade™ to function, and it functions on other computers; first try a different PS/2 Keyboard, then if that does not work, call **1-866-942-6464** for support. **NOTE:** For compatibility issues, if you test on another computer and the X-Arcade™ works, but it has problems on your computer, you should purchase our USB Adapter. Some computer's motherboards do not supply enough power to the PS/2 keyboard port to power the X-Arcade.™
- Playing with **MAME** or emulation software. You must use **MODE 1**. In the emulator's options menu, find controls, select X-Arcade™. Also, email the designer of the emulator creator and ask him to add a button configuration selection for the X-Arcade™.

### YOU MAY NEED OUR USB ADAPTER IF:

- If you notice that you cannot press one button to get response, but can press two buttons at once to generate key, your computer's PS/2 keyboard port does not supply enough power to run the X-Arcade™ on your PS/2 port. You will need to purchase our USB adapter.
- If your PC speaker beeps when you press buttons or directions on the X-Arcade™.
- If the Caps Lock or Num Lock come on by themselves, or menus are highlighted by themselves.
- If keyboard keys are double-typing letters or characters.
- If you get "keyboard error" when starting your PC with the X-Arcade™ connected.

- If you have a laptop with no PS/2 keyboard port, or you do not wish to use an external keyboard to use the X-Arcade™ on your laptop.
- If you do not wish to shut off your PC to disconnect from the keyboard port when you want to use the X-Arcade™ on a game console.
- If you have a wireless keyboard, or keyboard/mouse receiver.

### HOW DO I USE MY X-ARCADE™ WITH MAME FOR PC?

Before even starting to make your X-Arcade work with MAME, be sure it working with your PC first using the X-Arcade Test Program (available at [www.x-arcade.com](http://www.x-arcade.com)). Be sure your **NUM LOCK** is ON.

Once you have tested that the X-Arcade is working with the PC properly, be sure you are using the newest version of MAME32. Also be sure the X-Arcade™ is in **MODE 1** (switch on back closest to the serial connection) for MAME32. In MAME32, open Options (at the top), then Default Options, Game Controllers; then set your joystick to X-Arcade™ from the drop-down list. All of your MAME games will work with that configuration. Be sure the X-Arcade™ is plugged into the PC via PS/2 port or OUR USB adapter, and that the only keyboard is plugged into the X-Arcade™. If joystick 1 is the only thing not working, turn the **NUM LOCK (NLOCK)** key to ON on the keyboard. After you start a game, use the left pinball flipper button on the left side of the X-Arcade to insert coins, and press the white start button to play. You can also skip the screens which ask you to type OK by moving the joystick left then right.

### HOW CAN I USE MORE THAN 1 X-ARCADE™ ON MY PC?

You can plug one X-Arcade into the PS/2 keyboard port, and any others into USB ports using our USB adapter. You will need to reprogram the 2nd player. You cannot plug one X-Arcade™ into the other.

### MY KEYS SEEM TO BE PRESSING THE WRONG BUTTONS!

Move the mode selector switch to the far right, as described above. You may be in a programmed mode.

### I CAN'T MOVE AROUND IN THE CONSOLE GAME MENU!

The game you are playing may require that you use the digital control to navigate the menu. You might be in analog mode. Change the mode of your joystick as instructed in this manual.

### MY CONTROLLER IS TOO HEAVY

Use your handheld controller and hit the gym. Excalibur is a heavy sword. Good luck!



## MY PROGRAMMED LAYOUTS

**Mode 2**

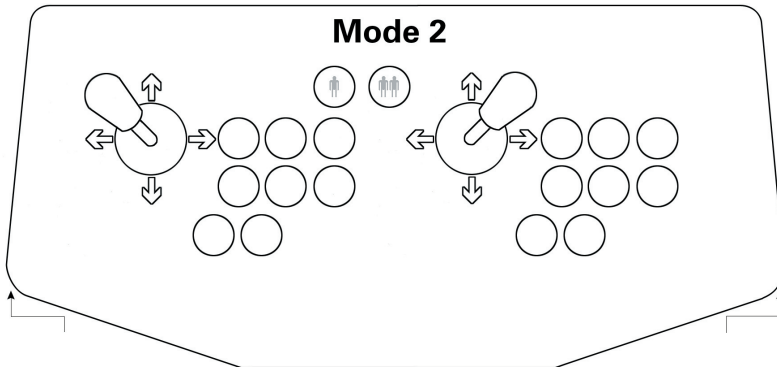

**Mode 3**

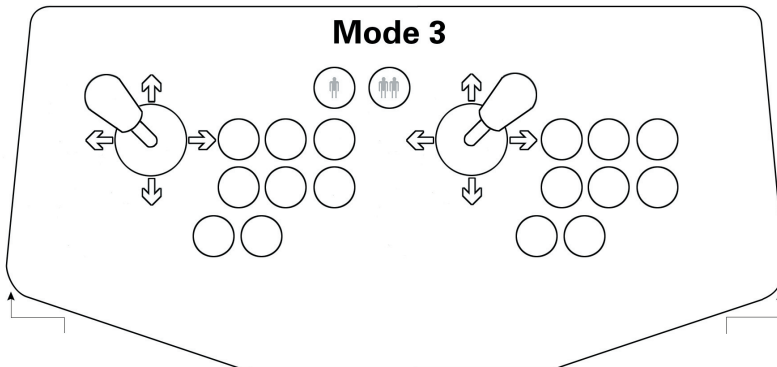

**Mode 4**

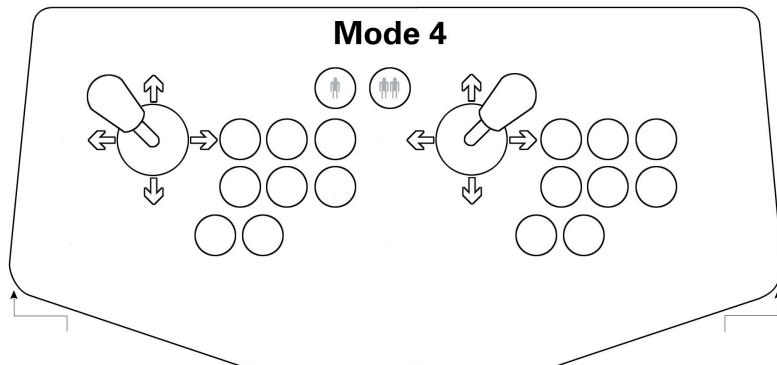

## WARRANTY

The X-Arcade™ is supported by XGAMING's industry leading service and support. XGAMING, INC Orders For X-Arcade Carry A Lifetime Warranty, serviced exclusively from XGAMING, INC. This means any defects or problems which occur during the life of purchaser's ownership of X-Arcade™ are covered under warranty. The X-Arcade™ warranty coverage is already recognized as one of the game industry's finest. Not only does XGAMING® cover your X-Arcade™ for the duration of the warranty, but XGAMING pays all fees and charges for shipping to/from your location. To explain further, if your X-Arcade™ is ever found defective or stops working, XGAMING® will arrange to ship a brand new X-Arcade™ to your location, and include a return shipping label with the new X-Arcade™ so you don't incur any shipping costs or fees. Any problems, call Toll Free Support at **1-866-942-6464** Monday – Friday, between 9 - 5PM Eastern, and you'll be sure to speak to a live person immediately. You can also find out information on our website at [www.XGaming.com](http://www.XGaming.com). This service is one of the many reasons XGAMING® has one of the best reputations in the video game industry.

All claims must be made directly to XGAMING® within the period of warranty with a proof of purchase from your retailer or distributor. Any items without a bill of sale will not be serviced and any returns or exchanges must be accompanied by first obtaining an RMA from XGAMING®, or if you purchased from one of our show dealers in your locale, please contact them directly on their receipt for quicker and easier, local service. NOTE: XGAMING® may deem that any and all warranty work can be done on site with customer replace-able parts replaced by customer. Please register your product online at [www.XGaming.com](http://www.XGaming.com) to activate your lifetime warranty.

**XGAMING®** warrants the X-Arcade™ Controller against defect in workmanship and materials as herein:

**Labor:** Lifetime; if XGAMING® determines that the equipment is defective subject to the limitations of this warranty, it will be replaced at no charge for labor.

**Parts:** Lifetime; XGAMING® will supply, at no charge, new parts to replace defective parts, against defect subject to limitations of the warranty.

These terms are for sales made directly by XGAMING® and differ from terms you may have to adhere to from the company you purchase the product from. You must register your product online at [www.xgaming.com](http://www.xgaming.com) to activate your lifetime warranty.

*XGAMING®, Inc., a California corporation, will not be held liable for any incidental or consequential damages for breach of any expressed or implied warranty of the X-Arcade™ controller, nor an incidental or consequential damages from the inability to use, or ability to use the controller. Under no circumstance shall XGAMING® Inc., liability exceed the purchase price of the product as sold by XGAMING® Inc. XGAMING® Inc. reserves the right to refuse to honor this warranty if any of above exceptions caused the product to no longer function correctly. This*